





SUBMITTAL DATA SHEET

AHU Heat Pump System

Location: _____
 Engineer: _____
 Submitted to: _____
 Submitted by: _____
 Reference: _____

Approval: _____
 Date: _____
 Construction: _____
 Unit #: _____
 Drawing #: _____

Set Code	22023110000889
Indoor unit code	22023111000272
Outdoor unit code	22023116000103
Set Model	
Indoor unit model	MIU-A48V-4
Outdoor unit model	MOU-A48V-4
Certified	
AHRI	
UL	



SYSTEM PERFORMANCE DATA

Power supply		
Normal Operational Voltage	(V, Ph, Hz)	208-230V, 1Ph, 60Hz
Voltage Range	(V)	187-253
Electrical		
Minimum circuit ampacity(Outdoor)	(A)	34.0
Max.fuse(Outdoor)	(A)	50.0
Connection wiring		14AWG*2 Stranded, shielded
Cooling		
Capacity	(Btu/h)	47000(10500~48000)
Power Input	(W)	5320(380~5290)
Current	(A)	23.2(2.9~24.1)
SEER2	(Btu/W)	15.8
EER2	(Btu/W)	8.8
Heating		
Capacity	(Btu/h)	55000(13500~57000)
Power Input	(W)	5117(760~5500)
Current	(A)	22.5(5.0~24.52)
HSPF2-4	(Btu/W)	9.4
HSPF2-5	(Btu/W)	7.5
COP	W/W	3.15
Heat at 17F(H32)	(Btu/h)	37000
Heat at 5F(H42)	(Btu/h)	36000
COP at 5F(H42)	W/W	1.95

REFRIGERANT PIPE DATA

Throttle type	Indoor unit	EEV for cooling
	Outdoor unit	EEV for heating
Design pressure	(PSIG)	550/340
Refrigerant Type		R410A
Refrigerant charge	oz	165.79
Refrigerant precharge	(ft)	25.0
	(m)	7.5
Additional charge for each ft	(oz/ft)	0.69
Additional charge for each m	(g/m)	65.0
Liquid side/ Gas side(indoor)	(inch)	3/8" / 3/4"
	(mm)	9.52/19
Liquid side/ Gas side(outdoor)	(inch)	3/8" / 3/4"
	(mm)	9.52/19
Max. pipe length	(ft)	213.3
	(m)	65.0
Max. difference in level	(ft)	98.4
	(m)	30.0
Connection method		Flared
Indoor(cooling)	(Deg. °F)	60~90
	(Deg. °C)	16~32
Indoor(heating)	(Deg. °F)	32~86
	(Deg. °C)	0~30
Outdoor(cooling)	(Deg. °F)	5~122
	(Deg. °C)	-15~50
Outdoor(heating)	(Deg. °F)	5~75
	(Deg. °C)	-15~24

INDOOR UNIT DATA

Indoor fan motor		
Model		ZKFD-560-8-1-1
Qty		1
Input	(W)	/
Output	(W)	/
RLA	(A)	46744.4
Speed(Hi/Mi/Lo)	(r/min)	/
Air flow & Noise level		
Indoor air flow (Hi/Med/Lo) (No duct)	(CFM)	470.59/1282.35/1094.12/905.88
Indoor noise level (Hi/Med/Lo)	[dB(A)]	53/50/46
Dehumidification	(L/H)	4.64
Indoor unit		
Dimension (WxDxH)	(inch)	21.02x21.02x49.02
	(mm)	534x534x1245
Packing(WxDxH)	(inch)	26.57x24.41x52.56
	(mm)	675x620x1335
Net/Gross weight	(lbs.)	130.51/156.31
	(kg)	59.2/70.9
Accessories		
Adaptor for welding(3/4")	Qty	1
Adaptor for welding(3/8")	Qty	1

OUTDOOR UNIT DATA

Compressor		
Type		ROTARY
Model		KTQ420D1UMU
Brand		GMCC
Capacity	(Btu/h)	46744
Input	(W)	3700
Rated current (RLA)	(A)	24
Refrigerant oil/oil charge	(ml)	VG74/1400
Outdoor fan motor		
Model		ZKFN-85-8-22-5
Qty		2
Input	(W)	126.0
Output	(W)	85
RLA	(A)	2.4
Speed	(r/min)	850/750/650
Air flow & Noise level		
Outdoor air flow (Max.)	(CFM)	4500
Outdoor noise level	[dB(A)]	59.0
Outdoor unit		
Dimension (WxDxH)	(inch)	37.48x16.34x52.48
	(mm)	952x415x1333
Packing (WxDxH)	(inch)	43.11x19.49x58.27
	(mm)	1095x495x1480
Net/ Gross weight	(lbs.)	217.59/248.68
	(kg)	98.7/112.8
Accessories		
Adaptor for welding(3/4")	Qty	1
Adaptor for welding(3/8")	Qty	1
Adaptor (5/8" to 3/4")	Qty	1

Indoor unit dimension

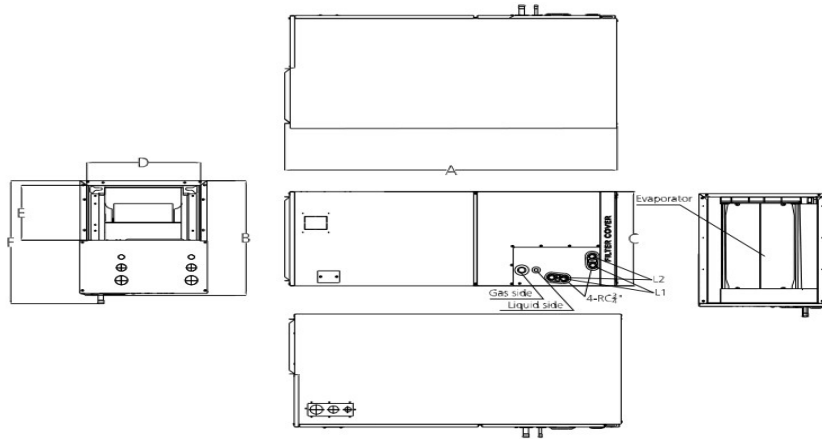

Model	Unit	Dimensions(mm)						Drain hole	
		A	B	C	D	E	F	L1	L2
18k~24k	mm	1143	534	445	400	260	585	Main drain	Overflow drain
	inch	45	21	17-1/2	15-3/4	10-1/4	23		
30k~48k	mm	1245	534	534	490	260	585		
	inch	49	21	21	19-5/16	10-1/4	23		
60k	mm	1346	534	622	580	260	585		
	inch	53	21	24-1/2	22-7/8	10-1/4	23		

Outdoor unit dimension

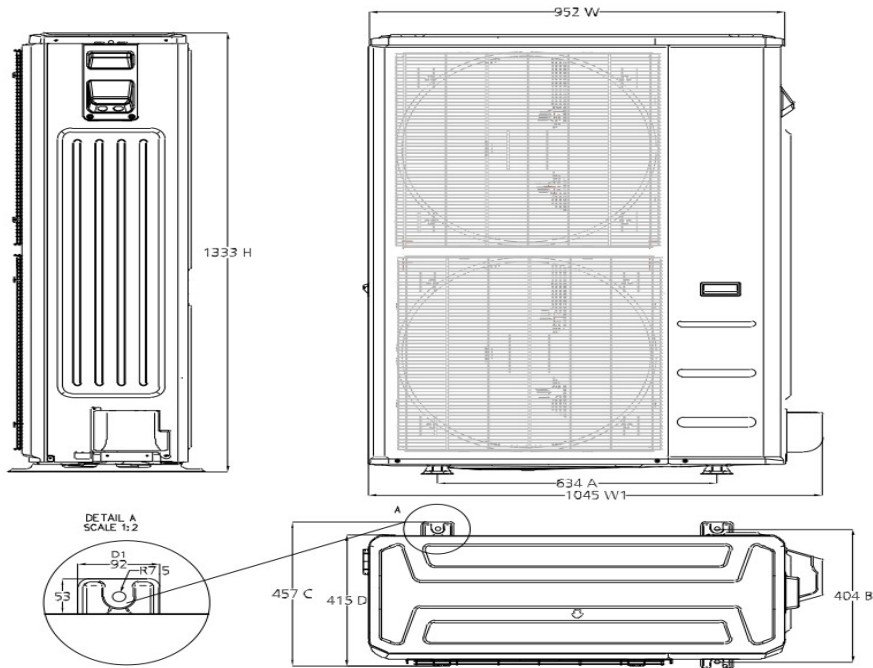

Fan performance

