

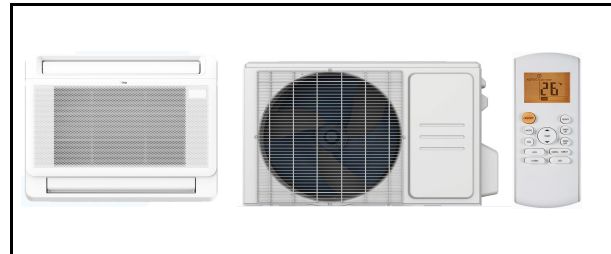

SUBMITTAL DATA SHEET

Console Heat Pump System	
Location: _____ Engineer: _____ Submitted to: _____ Submitted by: _____ Reference: _____	Approval: _____ Date: _____ Construction: _____ Unit #: _____ Drawing #: _____

Set Code	22022610000400
Indoor unit code	22022611000207
Outdoor unit code	22022016016220
Set Model	
Indoor unit model	MIU-B12F-2
Outdoor unit model	MOU-A12H-2
Certified	
AHRI	
UL	



SYSTEM PERFORMANCE DATA

Power supply		
Normal Operational Voltage	(V, Ph, Hz)	208/230V, 1Ph, 60Hz
Voltage Range	(V)	187-253
Electrical		
Minimum circuit ampacity(Outdoor)	(A)	15.0
Max.fuse(Outdoor)	(A)	15.0
Connection wiring		0
Cooling		
Capacity	(Btu/h)	12000(7600~14400)
Power Input	(W)	902(170~1230)
Current	(A)	4.13(1.42~5.51)
SEER2	(Btu/W)	24.2
EER2	(Btu/W)	13.3
Heating		
Capacity	(Btu/h)	12000(5000~15700)
Power Input	(W)	857(342~1450)
Current	(A)	4.12(1.81~6.64)
HSPF2-4	(Btu/W)	10.7
HSPF2-5	(Btu/W)	8.7
COP	W/W	4.10
Heat at 17F(H32)	(Btu/h)	10200
Heat at 5F(H42)	(Btu/h)	11900
COP at 5F(H42)	W/W	1.99

REFRIGERANT PIPE DATA

Throttle type	Indoor unit	N/A
	Outdoor unit	EXV
Design pressure	(PSIG)	550/340
Refrigerant Type		R410A
Refrigerant charge	oz	41.62
Refrigerant precharge	(ft)	0.0
	(m)	0.0
Additional charge for each ft	(oz/ft)	0.16
Additional charge for each m	(g/m)	15.0
Liquid side/ Gas side(indoor)	(inch)	1/4"/1/2"
	(mm)	6.35/12.7
Liquid side/ Gas side(outdoor)	(inch)	1/4"/1/2"
	(mm)	6.35/12.7
Max. pipe length	(ft)	82.0
	(m)	25.0
Max. difference in level	(ft)	32.8
	(m)	10.0
Connection method		Flared
Indoor(cooling)	(Deg. °F)	60~90
	(Deg. °C)	16~32
Indoor(heating)	(Deg. °F)	32~86
	(Deg. °C)	0~30
Outdoor(cooling)	(Deg. °F)	-22~122
	(Deg. °C)	-30~50
Outdoor(heating)	(Deg. °F)	-22~75
	(Deg. °C)	-30~24

INDOOR UNIT DATA

Indoor fan motor		
Model		ZKFP-13-8-136+ZKFP-13-8-104
Qty		1+1
Input	(W)	/
Output	(W)	13.0
RLA	(A)	0.50
Speed(Hi/Mi/Lo)	(r/min)	992/884/776
Air flow & Noise level		
Indoor air flow (Hi/Med/Lo) (No duct)	(CFM)	441.18/376.47/323.53/264.71
Indoor noise level (Hi/Med/Lo)	[dB(A)]	42/39/25
Dehumidification	(L/H)	1.4
Indoor unit		
Dimension (WxDxH)	(inch)	31.26x7.87x24.45
	(mm)	794x200x621
Packing(WxDxH)	(inch)	34.06x11.02x28.31
	(mm)	865x280x719
Net/Gross weight	(lbs.)	32.85/41.45
	(kg)	14.9/18.8

OUTDOOR UNIT DATA

Compressor		
Type		ROTARY
Model		KTN110D42UFZ
Brand		GMCC
Capacity	(Btu/h)	11823
Input	(W)	885
Rated current (RLA)	(A)	8.8
Refrigerant oil/oil charge	(ml)	VG74/350
Outdoor fan motor		
Model		ZKFN-34-10-1
Qty		1
Input	(W)	/
Output	(W)	34.00
RLA	(A)	0.36
Speed	(r/min)	850/680/450
Air flow & Noise level		
Outdoor air flow (Max.)	(CFM)	1323.5
Outdoor noise level	[dB(A)]	56.0
Outdoor unit		
Dimension (WxDxH)	(inch)	31.69x12.99x21.81
	(mm)	805x330x554
Packing (WxDxH)	(inch)	36.02x14.57x24.21
	(mm)	915x370x615
Net/ Gross weight	(lbs.)	73.63/79.37
	(kg)	33.4/36

Indoor unit dimension

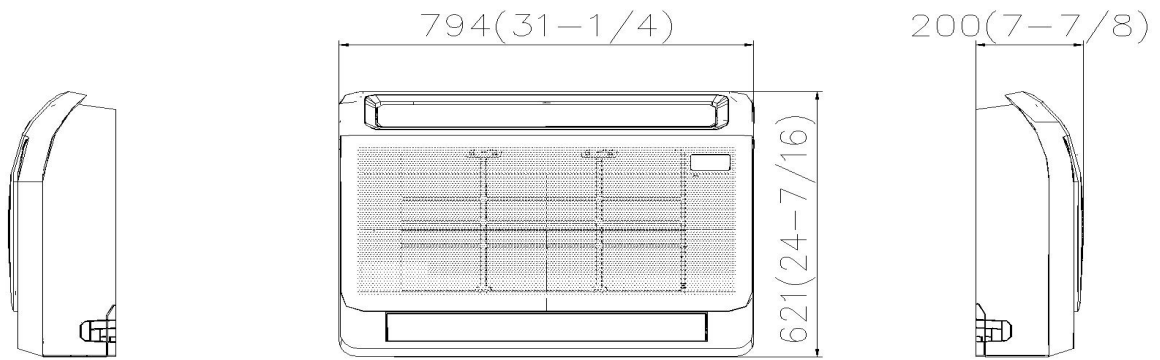

Outdoor unit dimension

