



SUBMITTAL DATA SHEET

One Way Cassette Heat Pump System	
Location: _____	Approval: _____
Engineer: _____	Date: _____
Submitted to: _____	Construction: _____
Submitted by: _____	Unit #: _____
Reference: _____	Drawing #: _____

Set Code	22022510004425
Indoor unit code	22022511003497
Outdoor unit code	22022516001922
Set Model	
Indoor unit model	MIU-A48LC-2
Outdoor unit model	MOU-A48LH-2
Certified	
AHRI	
CSA	



SYSTEM PERFORMANCE DATA

Power supply		
Normal Operational Voltage	(V, Ph, Hz)	208/230V, 1Ph, 60Hz
Voltage Range	(V)	187-253
Electrical		
Minimum circuit ampacity(Outdoor)	(A)	42.0
Max.fuse(Outdoor)	(A)	50.0
Connection wiring		14AWG*2 Stranded, shielded
Cooling		
Capacity	(Btu/h)	48000(2700~48900)
Power Input	(W)	6070(570~6100)
Current	(A)	25.24(4.30~25.80)
SEER2	(Btu/W)	16.8
EER2	(Btu/W)	8.3
Heating		
Capacity	(Btu/h)	53000(11800~58000)
Power Input	(W)	4900(870~5690)
Current	(A)	21.92(4.33~24.90)
HSPF2-4	(Btu/W)	10.7
HSPF2-5	(Btu/W)	8.5
COP	W/W	3.17
Heat at 17F(H32)	(Btu/h)	35000
Heat at 5F(H42)	(Btu/h)	48000
COP at 5F(H42)	W/W	1.98

REFRIGERANT PIPE DATA

Throttle type	Indoor unit	N/A
	Outdoor unit	EXV+Throttle valve
Design pressure	(PSIG)	550/340
Refrigerant Type		R410A
Refrigerant charge	oz	148.20
Refrigerant precharge	(ft)	25.0
	(m)	7.5
Additional charge for each ft	(oz/ft)	0.32
Additional charge for each m	(g/m)	30.0
Liquid side/ Gas side(indoor)	(inch)	3/8" / 5/8"
	(mm)	9.52/15.9
Liquid side/ Gas side(outdoor)	(inch)	3/8" / 5/8"
	(mm)	9.52/15.9
Max. pipe length	(ft)	213.3
	(m)	65.0
Max. difference in level	(ft)	98.4
	(m)	30.0
Connection method		Flared
Indoor(cooling)	(Deg. °F)	60~90
	(Deg. °C)	16~32
Indoor(heating)	(Deg. °F)	32~86
	(Deg. °C)	0~30
Outdoor(cooling)	(Deg. °F)	5~122
	(Deg. °C)	-15~50
Outdoor(heating)	(Deg. °F)	-22~75
	(Deg. °C)	-30~24

INDOOR UNIT DATA

Indoor fan motor		
Model		ZKFN-125-8-1
Qty		1
Input	(W)	157.00
Output	(W)	125.0
RLA	(A)	1.50
Speed(Hi/Mi/Lo)	(r/min)	800/730/660/590/456
Air flow & Noise level		
Indoor air flow (Turbo/Hi/Med/Lo)	(CFM)	288.24/1170.59/1058.82/935.29
Indoor noise level (Hi/Med/Lo)	[dB(A)]	55.5/52.5/50
Dehumidification	(L/H)	5.4
Indoor unit		
Dimension (WxDxH)	(inch)	32.68x32.68x11.30
	(mm)	830x830x287
Packing(WxDxH)	(inch)	35.83x35.83x12.99
	(mm)	910x910x330
Net/Gross weight	(lbs.)	64.59/74.07
	(kg)	29.3/33.6

OUTDOOR UNIT DATA

Compressor		
Type		ROTARY
Model		EAPQ420D1UMUA
Brand		GMCC
Capacity	(Btu/h)	44015
Input	(W)	3565
Rated current (RLA)	(A)	33.0
Refrigerant oil/oil charge	(ml)	1460±15mlESTER OIL VG74
Outdoor fan motor		
Model		ZKFN-85-8-22-5
Qty		2
Input	(W)	126.00
Output	(W)	85.00
RLA	(A)	1.20
Speed	(r/min)	900/850/800/750
Air flow & Noise level		
Outdoor air flow (Max.)	(CFM)	4500.0
Outdoor noise level	[dB(A)]	66.5
Outdoor unit		
Dimension (WxDxH)	(inch)	37.48x16.34x52.48
	(mm)	952x415x1333
Packing (WxDxH)	(inch)	43.11x19.49x58.27
	(mm)	1095x495x1480
Net/ Gross weight	(lbs.)	227.07/255.73
	(kg)	103/116

Indoor unit dimension

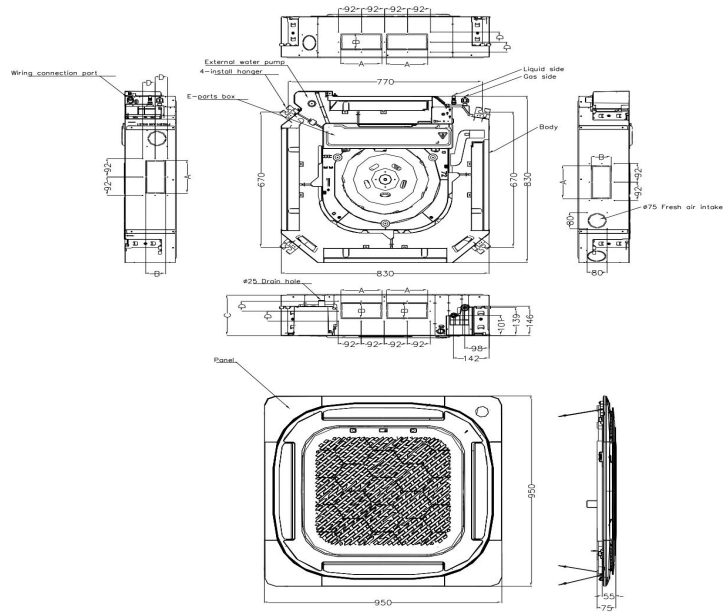

Capacity (Btu/h)	Unit	A	B	C	D
24K	mm	165	80	205	50
	inch	6.5	3.15	8.07	1.97
36K	mm	165	100	245	60
	inch	6.5	3.64	9.65	2.36
48K	mm	165	100	287	60
	inch	6.5	3.64	11.30	2.36

Outdoor unit dimension

