





SUBMITTAL DATA SHEET

Wall Mounted Heat Pump System	
Location: _____	Approval: _____
Engineer: _____	Date: _____
Submitted to: _____	Construction: _____
Submitted by: _____	Unit #: _____
Reference: _____	Drawing #: _____

Set Code	22022010017977
Indoor unit code	22022011016725
Outdoor unit code	22022016015920
Set Model	
Indoor unit model	MIU-A24W-2
Outdoor unit model	MOU-A24H-2
Certified	
AHRI	
UL	
	



SYSTEM PERFORMANCE DATA

Power supply		
Normal Operational Voltage	(V, Ph, Hz)	208/230V, 1Ph, 60Hz
Voltage Range	(V)	187-253
Electrical		
Minimum circuit ampacity(Outdoor)	(A)	25.0
Max.fuse(Outdoor)	(A)	35.0
Connection wiring		14AWG*4
Cooling		
Capacity	(Btu/h)	23000(4650~26600)
Power Input	(W)	1840(484~2540)
Current	(A)	8.25(2.1~11)
SEER2	(Btu/W)	22.3
EER2	(Btu/W)	12.5
Heating		
Capacity	(Btu/h)	26000(9550~27000)
Power Input	(W)	2540(810~3090)
Current	(A)	11.38(3.5~13.4)
HSPF2-4	(Btu/W)	10.3
HSPF2-5	(Btu/W)	7.7
COP	W/W	3.00
Heat at 17F(H32)	(Btu/h)	18900
Heat at 5F(H42)	(Btu/h)	23000
COP at 5F(H42)	W/W	1.80

REFRIGERANT PIPE DATA

Throttle type	Indoor unit	N/A
	Outdoor unit	EXV+Throttle valve
Design pressure	(PSIG)	550/340
Refrigerant Type		R410A
Refrigerant charge	oz	91.71
Refrigerant precharge	(ft)	25.0
	(m)	7.5
Additional charge for each ft	(oz/ft)	0.32
Additional charge for each m	(g/m)	30.0
Liquid side/ Gas side(indoor)	(inch)	3/8"/5/8"
	(mm)	9.52/15.9
Liquid side/ Gas side(outdoor)	(inch)	3/8"/5/8"
	(mm)	9.52/15.9
Max. pipe length	(ft)	164.0
	(m)	50.0
Max. difference in level	(ft)	82.0
	(m)	25.0
Connection method		Flared
Indoor(cooling)	(Deg. °F)	60~90
	(Deg. °C)	16~32
Indoor(heating)	(Deg. °F)	32~86
	(Deg. °C)	0~30
Outdoor(cooling)	(Deg. °F)	-22~122
	(Deg. °C)	-30~50
Outdoor(heating)	(Deg. °F)	-22~75
	(Deg. °C)	-30~24

INDOOR UNIT DATA

Indoor fan motor		
Model		ZKFP-58-8-1-5
Qty		1
Input	(W)	58.00
Output	(W)	58.0
RLA	(A)	0.4
Speed(Hi/Mi/Lo)	(r/min)	1200/1080/600
Air flow & Noise level		
Indoor air flow (Hi/Med/Lo) (No duct)	(CFM)	760.59/601.18/458.82/382.35
Indoor noise level (Hi/Med/Lo)	[dB(A)]	46.5/44/35
Dehumidification	(L/H)	2.43
Indoor unit		
Dimension (WxDxH)	(inch)	42.60x9.21x13.27
	(mm)	1082x234x337
Packing(WxDxH)	(inch)	45.47x16.34x12.40
	(mm)	1155x415x315
Net/Gross weight	(lbs.)	29.98/38.14
	(kg)	13.6/17.3

OUTDOOR UNIT DATA

Compressor		
Type		Twin-ROTARY
Model		KTM240D43UKT
Brand		GMCC
Capacity	(Btu/h)	25931
Input	(W)	2045
Rated current (RLA)	(A)	17.1
Refrigerant oil/oil charge	(ml)	ESTER OIL VG74 620
Outdoor fan motor		
Model		ZKFN-120-8-2
Qty		1
Input	(W)	150.0
Output	(W)	120
RLA	(A)	0.5
Speed	(r/min)	950/800/500
Air flow & Noise level		
Outdoor air flow (Max.)	(CFM)	2235
Outdoor noise level	[dB(A)]	62.5
Outdoor unit		
Dimension (WxDxH)	(inch)	37.24x16.14x31.89
	(mm)	946x410x810
Packing (WxDxH)	(inch)	42.91x19.69x34.84
	(mm)	1090x500x885
Net/ Gross weight	(lbs.)	134.48/144.40
	(kg)	61/65.5

Indoor unit dimension

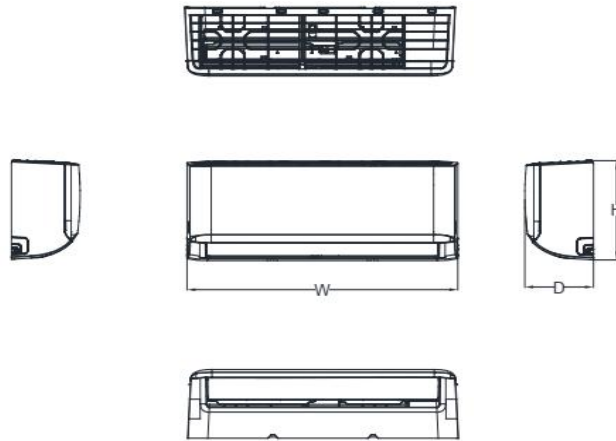

Capacity	Body Code	W(mm/inch)	D(mm/inch)	H(mm/inch)
6K~11K	A	729/28.7	200/7.87	292/11.5
8K~14K	B	802/31.57	200/7.87	295/11.61
12K~21K	C	971/38.23	228/8.98	321/12.64
18K~28K	D	1082/42.6	234/9.21	337/13.27
27K~36K	F	1259/49.57	283/11.14	362/14.25

Outdoor unit dimension

