



SUBMITTAL DATA SHEET

Wall Mounted Heat Pump System	
Location: _____	Approval: _____
Engineer: _____	Date: _____
Submitted to: _____	Construction: _____
Submitted by: _____	Unit #: _____
Reference: _____	Drawing #: _____

Set Code	22022010018241
Indoor unit code	22022011016701
Outdoor unit code	22022016016220
Set Model	
Indoor unit model	MIU-A12W-2
Outdoor unit model	MOU-A12H-2
Certified	
AHRI	
UL	



SYSTEM PERFORMANCE DATA

Power supply		
Normal Operational Voltage	(V, Ph, Hz)	208/230V, 1Ph, 60Hz
Voltage Range	(V)	187-253
Electrical		
Minimum circuit ampacity(Outdoor)	(A)	15.0
Max.fuse(Outdoor)	(A)	15.0
Connection wiring		14AWG*4
Cooling		
Capacity	(Btu/h)	12000(3700~13300)
Power Input	(W)	923(200~1150)
Current	(A)	2.5(0.86~5)
SEER2	(Btu/W)	23.1
EER2	(Btu/W)	13.0
Heating		
Capacity	(Btu/h)	12000(5100~14300)
Power Input	(W)	978(350~1400)
Current	(A)	4.25(1.5~6.0)
HSPF2-4	(Btu/W)	10.5
HSPF2-5	(Btu/W)	8.0
COP	W/W	3.60
Heat at 17F(H32)	(Btu/h)	10300
Heat at 5F(H42)	(Btu/h)	11000
COP at 5F(H42)	W/W	1.88

REFRIGERANT PIPE DATA

Throttle type	Indoor unit	N/A
	Outdoor unit	EXV
Design pressure	(PSIG)	550/340
Refrigerant Type		R410A
Refrigerant charge	oz	41.62
Refrigerant precharge	(ft)	25.0
	(m)	7.5
Additional charge for each ft	(oz/ft)	0.16
Additional charge for each m	(g/m)	15.0
Liquid side/ Gas side(indoor)	(inch)	1/4"/1/2"
	(mm)	6.35/12.7
Liquid side/ Gas side(outdoor)	(inch)	1/4"/1/2"
	(mm)	6.35/12.7
Max. pipe length	(ft)	82.0
	(m)	25.0
Max. difference in level	(ft)	32.8
	(m)	10.0
Connection method		Flared
Indoor(cooling)	(Deg. °F)	60~90
	(Deg. °C)	16~32
Indoor(heating)	(Deg. °F)	32~86
	(Deg. °C)	0~30
Outdoor(cooling)	(Deg. °F)	-22~122
	(Deg. °C)	-30~50
Outdoor(heating)	(Deg. °F)	-22~75
	(Deg. °C)	-30~24

INDOOR UNIT DATA

Indoor fan motor		
Model		ZKFP-13-8-4
Qty		1
Input	(W)	/
Output	(W)	13.0
RLA	(A)	0.4
Speed(Hi/Mi/Lo)	(r/min)	1250/950/750
Air flow & Noise level		
Indoor air flow (Hi/Med/Lo) (No duct)	(CFM)	341.18/291.18/194.12/152.94
Indoor noise level (Hi/Med/Lo)	[dB(A)]	41.5/36/24
Dehumidification	(L/H)	1.45
Indoor unit		
Dimension (WxDxH)	(inch)	31.57x7.87x11.61
	(mm)	802x200x295
Packing(WxDxH)	(inch)	34.45x11.22x14.96
	(mm)	875x285x380
Net/Gross weight	(lbs.)	18.74/24.25
	(kg)	8.5/11

OUTDOOR UNIT DATA

Compressor		
Type		ROTARY
Model		KTN110D42UFZ
Brand		GMCC
Capacity	(Btu/h)	11823
Input	(W)	885
Rated current (RLA)	(A)	8.8
Refrigerant oil/oil charge	(ml)	VG74/350
Outdoor fan motor		
Model		ZKFN-34-10-1
Qty		1
Input	(W)	/
Output	(W)	34
RLA	(A)	0.4
Speed	(r/min)	850/680/450
Air flow & Noise level		
Outdoor air flow (Max.)	(CFM)	1324
Outdoor noise level	[dB(A)]	56.0
Outdoor unit		
Dimension (WxDxH)	(inch)	31.69x12.99x21.81
	(mm)	805x330x554
Packing (WxDxH)	(inch)	36.02x14.57x24.21
	(mm)	915x370x615
Net/ Gross weight	(lbs.)	73.63/79.37
	(kg)	33.4/36

Indoor unit dimension

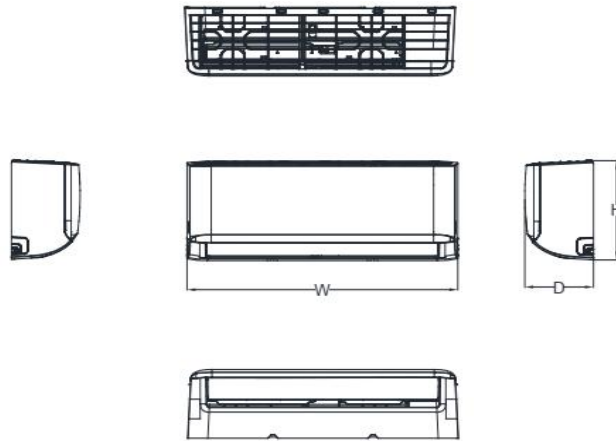

Capacity	Body Code	W(mm/inch)	D(mm/inch)	H(mm/inch)
6K~11K	A	729/28.7	200/7.87	292/11.5
8K~14K	B	802/31.57	200/7.87	295/11.61
12K~21K	C	971/38.23	228/8.98	321/12.64
18K~28K	D	1082/42.6	234/9.21	337/13.27
27K~36K	F	1259/49.57	283/11.14	362/14.25

Outdoor unit dimension

